

No Sound Series



270 NS

Certified for:

- Sound insulation **53 dB**
- Fire resistance: **60 min.**
- Usage cycles **200.000 cycles**

Protects from:

- Air
- Water
- Light
- Insects

Not an obstacle for disabled persons

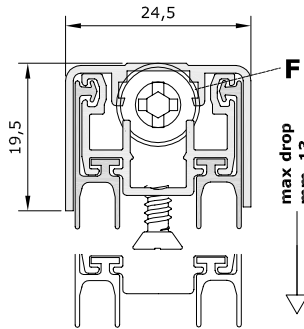

STANDARD ACCESSORIES

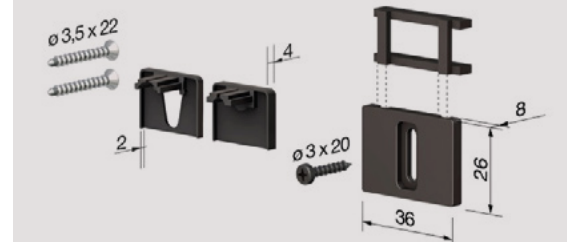

Standard measurements (mm)	330	430	530	630	730	830	930	1030	1130	1230	1330
Max shortening (mm)	70	130	200	200	200	200	200	200	200	200	200

FASTENING SYSTEMS

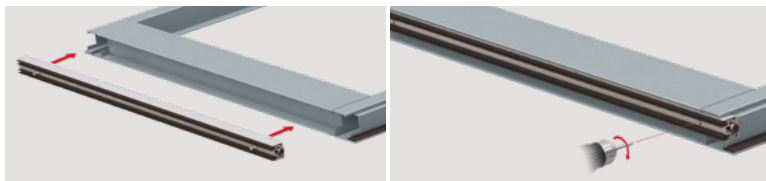

With pre-mounted screws

Mechanism with a single adjustment (screw F: descent) characterised by the controlled movement of the moving profile with gasket (immediate descent from the hinge side of the door and consequent gradual descent for the entire length) for adjustment to the floor.

STANDARD: Cardboard box with 25 pcs + 25 standard accessory packs.

MAIN APPLICATIONS

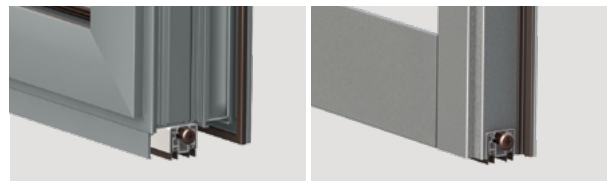

Aluminium door

Steel door

Extruded profiles in aluminium alloy 6060 - dual high performance silicone lamellar gasket - elements printed in self-lubricating nylon + nylon reinforced with 30% glass fibre - threaded rods in burnished iron - Ø 5 mm brass bushing - coil springs in treated stainless steel - self-drilling 3,5 x 22 mm screws.

OPTIONAL ACCESSORIES

Details on page 102

1 Nylon plate

CA102	CA103	CA104	AE	100 pcs pack brown, white
CA201	CA202	CA203	CA204	
CA205	CA207			

2 Insulating nylon plate with silicon gasket

PI002	PI002-R	20 pcs pack brown, white
PI003	PI004	
	PI005	

Application examples

Frame with ribbing

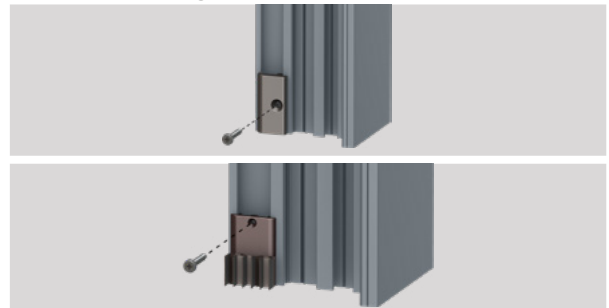

BUTTON (F): hexagonal brass, square nylon, bevelled nylon, rolling nylon (pivot).
GASKET: high performance wrap-around silicone (art. 1370NS, p. 72)

OPTIONAL: Cardboard box with 15 polyethylene bags with 1 pc + 1 standard accessory pack + assembly instructions