





Special Series 1370

Certified for:

 Usage cycles **200.000**

Protects from:

-  Air
-  Water
-  Light
-  Insects

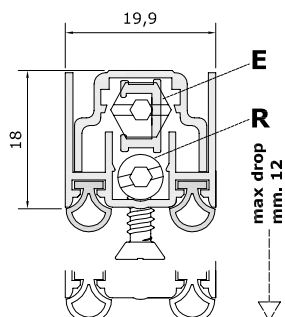

 Not an obstacle for disabled persons

STANDARD ACCESSORIES

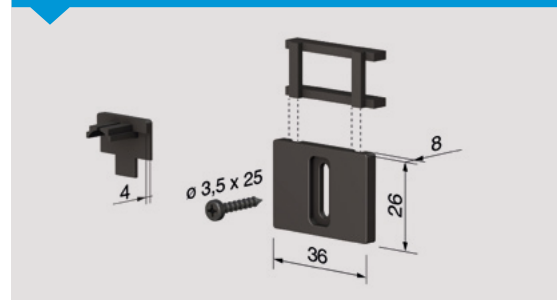

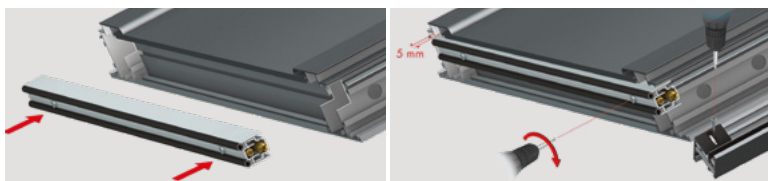

Standard measurements (mm)	530	630	730	830	930	1030	1130	1230	1330
Max shortening (mm)	100	100	100	100	100	100	100	100	100

FASTENING SYSTEMS



With pre-mounted screws

 Mechanism (PATENTED) with the parallel descent of the moving profile with gasket, characterised by the DUAL ADJUSTMENT (screw E: descent - screw R: incline) for a strong even pressure on the entire length.

 **STANDARD:** Cardboard box with 30 pcs + 30 standard accessory packs.

MAIN APPLICATIONS

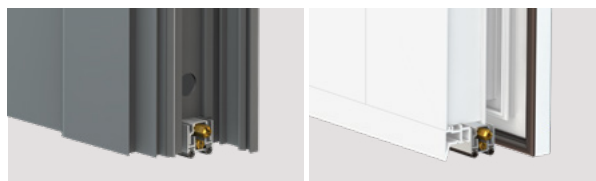

Aluminium door

PVC doors



Extruded profiles in aluminium alloy 6060 - dual extruded tubular neoprene gasket - elements printed in self-lubricating nylon + nylon reinforced with 30% glass fibre - threaded rods in burnished iron - 7 mm hexagonal button and Ø 6 mm brass bushing - coil springs in treated stainless steel - self-drilling 3,5 x 22 mm screws.



OPTIONAL ACCESSORIES

Details on page 102

1 Nylon plate

CA104				 100 pcs pack
CA201	CA202	CA203	CA204	 brown, white
CA205	CA207			

2 Insulating nylon plate with silicon gasket

PI001	PI002	PI002-R	 20 pcs pack
PI003	PI004	PI005	 brown, white

Application examples

Frame with ribbing

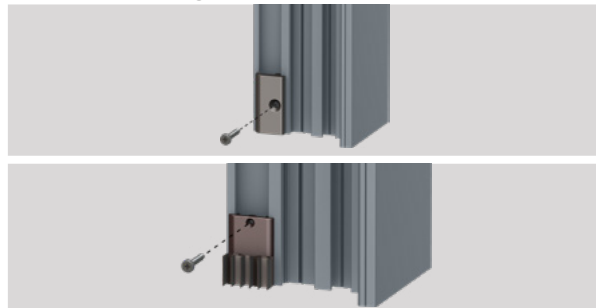

 **BUTTON (E):** round nylon, square nylon, bevelled nylon, rolling nylon (pivot).

 **OPTIONAL:** Cardboard box with 15 polyethylene bags with 1 pc + 1 standard accessory pack + assembly instructions.