

Universal Series 1350

Protects from:



Air



Water



Light



Insects



Not an obstacle for disabled persons

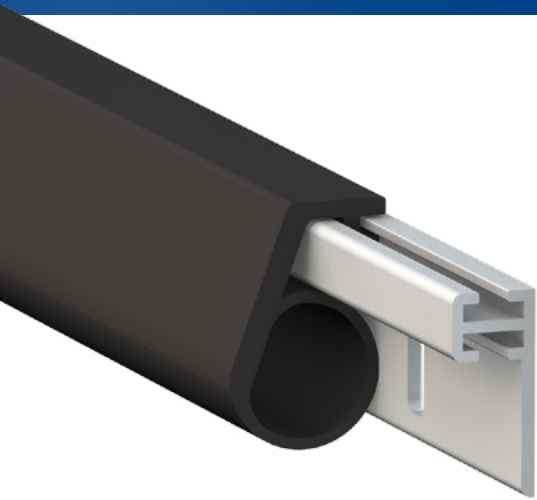

STANDARD ACCESSORIES



DIMENSIONS: 80 - 100 - 120.

FEATURES: Fixed draught excluder with EPDM gasket.

COMPONENTS: Profiles in aluminium alloy 6060, EPDM gasket.

PACKAGING: 15 pcs box.

FASTENING SYSTEMS



Screw

MAIN APPLICATIONS

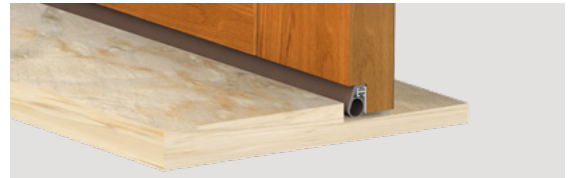

Wooden door with raised threshold

Universal Series 1355

Protects from:



Air



Water



Light



Insects



Not an obstacle for disabled persons

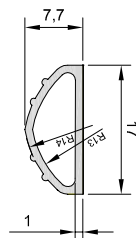
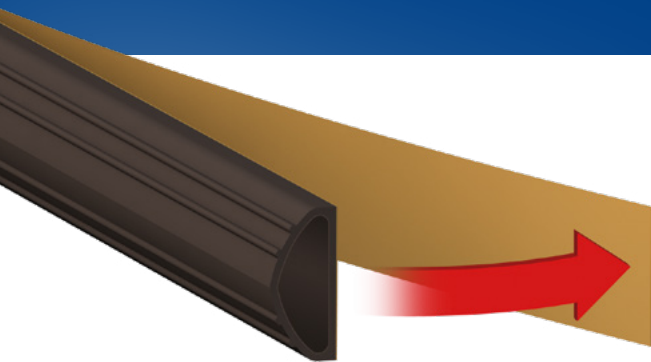

FEATURES: Adhesive tubular seal around frame and door.

COMPONENTS: EPDM gasket, adhesive strip.

PACKAGING: Single pack with 6 mt coil.

FASTENING SYSTEMS



Adhesive

MAIN APPLICATIONS

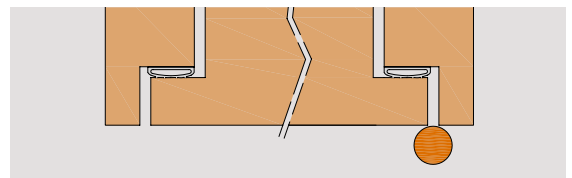

Wood door